

TORHEL 900-series

Battery Load Unit

User's Manual



Megger

WWW.MEGGER.COM

TORKEL 900-series

Battery Load Unit

User's Manual

NOTICE OF COPYRIGHT & PROPRIETARY RIGHTS

© 2016, Megger Sweden AB. All rights reserved.

The contents of this manual are the property of Megger Sweden AB. No part of this work may be reproduced or transmitted in any form or by any means, except as permitted in written license agreement with Megger Sweden AB. Megger Sweden AB has made every reasonable attempt to ensure the completeness and accuracy of this document. However, the information contained in this manual is subject to change without notice, and does not represent a commitment on the part of Megger Sweden AB. Any attached hardware schematics and technical descriptions, or software listings that disclose source code, are for informational purposes only. Reproduction in whole or in part to create working hardware or software for other than Megger Sweden AB products is strictly prohibited, except as permitted by written license agreement with Megger Sweden AB.

TRADEMARK NOTICES

Megger® and Programma® are trademarks registered in the U.S. and other countries. All other brand and product names mentioned in this document are trademarks or registered trademarks of their respective companies.

Megger Sweden AB is certified according to ISO 9001 and 14001.

Postal address:

Megger Sweden AB
Box 724
SE-182 17 DANDERYD
SWEDEN

Visiting address:

Megger Sweden AB
Rinkebyvägen 19
SE-182 36 DANDERYD
SWEDEN

T +46 8 510 195 00 seinfo@megger.com
F +46 8 510 195 95 www.megger.com



Contents

1 Introduction

.....	6
1.1 Product description	6
1.2 Features and benefits	6
Model overview	6
1.3 Receiving instructions.....	7
1.4 Warranty	7
Warranty repair	7

2 Safety

.....	8
2.1 Symbols on the instrument	8
2.2 Safety instructions.....	8
Protection system	9

3 TORHEL panels

.....	10
3.1 Top panel.....	10
3.2 Side panel.....	11

4 Menu system

.....	12
4.1 Main menu	12
Screen buttons.....	12
TEST menu.....	12
GRAPH.....	14
RESULT.....	15
REPORT.....	15
CELLS (optional BVM).....	15
4.2 TORHEL Viewer	16
Optional.....	16
TORHEL Calc	16

5 Making a test

.....	18
5.1 Preparations for testing.....	18
Connecting the current cables to the battery.....	18
Emergency stop button	18
5.2 Test at constant current.....	19
Preparations.....	19
Select "Test Method"	19
Starting the test	19
Pausing the test	19
Ending the test.....	19
5.3 Test at constant power.....	20
Preparations.....	20
Configuring TORHEL for constant power.....	20
Select "Test Method"	20
Starting the test	20
Pausing the test	20
Ending the test.....	20

5.4 Test at constant resistance	21
Preparations.....	21
Select "Test Method"	21
Starting the test	21
Pausing the test	21
Ending the test.....	21
5.5 Testing with a load profile	22
Preparations.....	22
Select "Test Method"	22
Starting the test	22
Pausing the test	22
Ending the test.....	22
5.6 V Logger.....	23
Starting "V Logger" directly after a discharge test.....	23
Starting "V Logger" as a separate test	23
Ending the test.....	23
5.7 Viewing results and reporting	24
Viewing the results.....	24
REPORT.....	24

6 External current measurement

26	
6.1 General.....	26
6.2 Setting up external current measurement...26	
DC clamp-on ammeter.....	26
Troubleshooting	27
6.3 Applications	27
TORHEL used together with TXL Extra Load.....	27
Multiple units used together	27
Constant current, regular load connected.....	28
Battery cables.....	28
Optional cables	28
Optional Clamp-on DC ammeter	28

7 Alarm function

.....	30
7.1 Description	30
Resetting the alarm	30

8 How to obtain the desired current....

32	
8.1 When a single TORHEL isn't enough.....	32
TXL Extra Loads connected to TORHEL	32
Calculating how many TORHELs and TXLs are needed	32
TORHEL 930	33

9 Optional equipment

.....	34
9.1 TXL830/850/870/890 (Extra Loads)	34
Panel.....	34
Using the TXL.....	34
Testing	35
9.2 BVM - Battery Voltage Monitor	35
Power & signal connector unit.....	36

Test setup.....	36
Optional BVM equipment.....	37
10 Troubleshooting	
.....	38
Messages on display.....	38
11 Specifications	
.....	40
TORHEL 900-series.....	40
BVM.....	42
Index	44

1 Introduction

1.1 Product description

This manual explains how to use TORHEL 900-series of battery load units, and it also covers the optional TXL (extra load units) and the BVM (Battery Voltage Monitor) system.

The instrument is designed mainly for capacity tests. The unit can be programmed to test a battery bank at constant current, constant power, constant resistance or using a user-defined load profile. TORHEL can also be used for testing battery chargers and other electrical equipment that require resistive load testing.

The BVM (Battery Voltage Monitor) is a battery voltage measurement device that is used for monitoring of cell voltages and battery blocks in battery banks commonly found in electrical power sub-stations, telecom facilities and computer data center UPS systems.

1.2 Features and benefits

Model overview

	TORHEL 910	TORHEL 930
Current (max)	110 A	220 A
BVM functionality	No	Yes
Charging measurement	No	Yes
Full report functionality Tests can be saved for further handling on PC	No	Yes
TORHEL Viewer	No	Yes

1.3 Receiving instructions

- Check the equipment received against the packing list to ensure that all materials are present. Notify Megger of any shortage.
- Examine the instrument for damage received in transit. If damage is discovered, file a claim with the carrier at once and notify Megger, giving a detailed description of the damage.
- This instrument has been thoroughly tested and inspected to meet rigid specifications before being shipped. It is ready for use when set up as indicated in this user manual.

1.4 Warranty

Products supplied by Megger are warranted against defects in material and workmanship for a period of one year following shipment.

Our liability is specifically limited to replacing or repairing, at our option, defective equipment.

This warranty does not include batteries, lamps or other expendable items, where the original manufacturer's warranty shall apply.

We make no other warranty. The warranty is void in the event of negligence abuse (failure to follow recommended operating procedures) or failure by the customer to perform specific maintenance as indicated in this manual.

Warranty repair

Equipment returned to the factory for repair must be shipped prepaid and insured.

Contact your Megger representative for instructions and a return authorization (RA) number.

Please indicate all pertinent information, including problem symptoms.

Also specify the serial number and the catalog number of the unit.

2 Safety

2.1 Symbols on the instrument



Caution, refer to accompanying documents.



Caution, risk of electric shock.



Hot, do not cover



Protective conductor terminal.



WEEE, Waste Electrical and Electronic Equipment. Please utilize your local WEEE collection facilities in the disposition of this product and otherwise observe all applicable requirements.

2.2 Safety instructions

- All safety and operating instructions must be read before using TORKEL.
- All safety and operating instructions for TORKEL must be followed.
- All safety and operating instructions must be retained for future reference.



WARNING

1. The electrical voltage and current used in battery testing is potentially lethal. Ensure that the AC supply is disconnected and any battery under test is disconnected before attempting any cleaning or maintenance of TORKEL.
2. Connection and disconnection procedures are extremely important. Be sure to follow the instructions carefully.
3. Do not touch conducting parts of the clamps on the current cables or the voltage sensing cables when they are connected to TORKEL.
4. Never connect a TORKEL to a voltage higher than specified.
5. Misuse of TORKEL can be extremely dangerous.
6. Inspect cable connections to make sure there is no short circuit.
7. Use an easily accessible power outlet. This will ensure that you can disconnect the power quickly in case of a problem.
8. When a lead acid battery is charged or discharged i.e. when there is a current flow through the battery it is always a risk that the battery can explode. If there is a bad connection inside the battery and there is a current flow - the connection will burn off and there will be an arc, which will ignite the oxyhydrogen gas in the battery. For new open (vented) batteries the risk is medium to low but in old VRLA (sealed) batteries the risk is medium to high.
9. To minimize the risk for personnel injuries: Always place TORKEL/TXL as far away from the battery as possible. Never stand close to a battery during charge/discharge.

- | | |
|--|--|
| <p>10. Too high discharge current applied on a battery can cause the battery to explode or get overheated. Be sure to not set too high current.</p> | <p>4. At high ambient temperatures and high loads, TORKEL will employ a heat reduction discharge scheme that under certain circumstances might induce a high frequency audible noise. This is normal, but can be taken as an indication that TORKEL is working close to its temperature limits.</p> |
| <p>11. If the external current measurement is interrupted or giving false values during the test, the current will rise to a higher level than the set value before the test is shut down. If the battery is too small for this current or in a bad condition - it may explode.</p> | |
| <p>12. Never use the TORKEL/TXL Extra Load in an explosive environment. Never put the TORKEL/TXL Extra Load where it can be reached by battery gas.</p> | |
| <p>13. Improperly connected cables carrying high current can cause fire. Make sure that the cables are not twisted in such a way that could cause them to turn and come loose from the connector.</p> | |
| <p>14. Make sure that there is no dust or dirt in or around the cooling fans before starting a discharge test. After starting a discharge test, check that the fans are running properly and that the airflow is good. Make sure no hair or clothing is sucked into the fans.</p> | |
| <p>15. Position TORKEL/TXL Extra Load where air flow is unobstructed and where it does not come into contact with any flammable or heat-sensitive material. Keep a free distance of 1.5 m (5 ft) to the vertical sides of TORKEL/TXL and 2.0 m (6.5 ft) above TORKEL/TXL.</p> | |
| <p>16. Do not place TORKEL a) near another TORKEL, a TXL Extra Load or any other heat source or b) where the cooling airflow can be blocked. TORKEL will overheat if there is insufficient cooling.</p> | |
| <p>17. External current shunt may not be used above 300 V DC</p> | |
| <p>18. Do not use any other equipment other than what is provided or specified.</p> | |



Important

- | | |
|-----------|--|
| 1. | When using the external current measurement function: <ul style="list-style-type: none"> ■ Always replace the CT internal battery before a test or use the 9 V DC out from TORKEL. ■ Set the correct current ratio in the external current measurement menu. |
| 2. | Do not use liquid detergents or aero-sols when cleaning TORKEL or TXL units. Use a damp cloth. |
| 3. | If TORKEL has been stored below freezing for an extended period of time, you must allow 3 hours for it to adapt to room temperature. |

Protection system

The unit has built-in protection system against overheating and malfunctioning cooling fans. A built-in circuit breaker is an important component in the safety system. If the temperature will be too high and/or the cooling fans malfunction, the circuit breaker will trip. There is also a melting fuse connected in series with the circuit breaker.

Always follow the safety instructions in section 2.2.

3 TORHEL panels

3.1 Top panel



- 1. TXL STOP**
Output used for stop discharging from an external device (TXL). Galvanically isolated.
- 2. SERVICE**
Connector for service purposes only.
- 3. ALARM**
Output equipped with a relay contact for triggering an external alarm device.
- 4. DC OUT**
9 V output for external current clamp.
- 5. I EXT ≤ 1 V**
Input used to measure current in an external path by means of a clamp-on-probe or a current shunt.
- 6. Display**
Touch screen 7"
- 7. BVM1, BVM2**
USB connections for BVM units.
- 8. USB connection**
For USB memory stick.
- 9. Ethernet connection**
For service of the instrument.
- 10. EMERGENCY STOP**
Push to stop.
The connection to the test object (battery bank) is interrupted in the same way as if mains would fail. In addition, a separate signal will stop the electronics and the discharge process stops.
The emergency stop works even if the electronics fail.
Reset the button by turning it right
- 11. Control knob**
For entering settings etc. Press to confirm a setting.
- 12. Buzzer**
For alarms.
- 13. ON/OFF switch**

3.2 Side panel

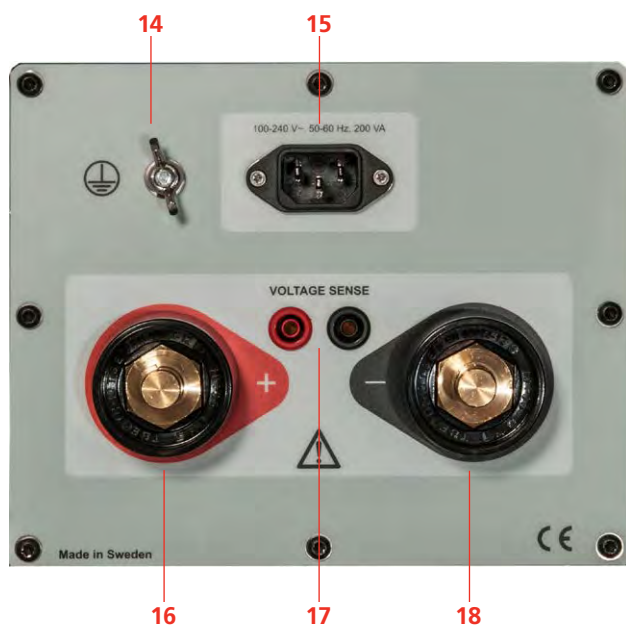

14. Protective conductor terminal

15. MAINS

Connector for mains supply.

16. +

Connection terminal (+) for the battery (or other DC source)

17. VOLTAGE SENSE

Input for sensing voltage at the battery terminals. Impedance to the battery current terminals is $>1\text{ M}\Omega$













18. -

Connection terminal (-) for the battery (or other DC source).

4 Menu system

4.1 Main menu

Screen buttons

	Confirm
	Exit without changes
	Run
	Pause the test to make any corrections/changes in the settings ^{*)}
	Stop
	Temperature compensation Shown when compensation is enabled
	Quick guide
	Open test file library
	New test
	Test configuration
	Information bar Shows messages and is used for acknowledge alarms
	Information field Shows voltage and current

^{*)} The pause time has limitations regulated by international standards. If the pause time is too long the battery may have to be recharged before a new test is done.

TEST menu

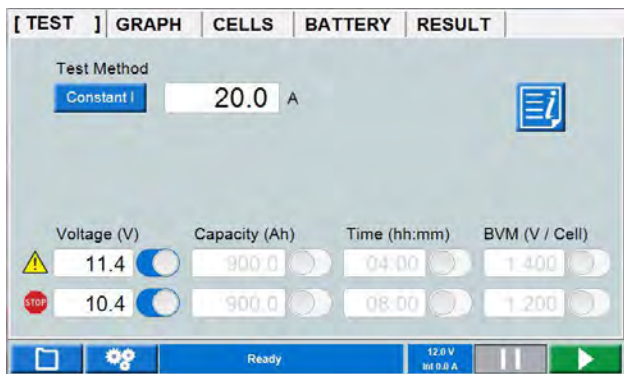

Test method

A test can be made in six test methods, "Constant I" is default.

1] Press the button and select test method.

- Constant I (current)
- Constant P (power)
- Constant R (resistance)
- Profile I (current profile)
- Profile P (power profile)
- V Logger (Current with monitoring during charge)

A] For **Constant I, P or R** you press the numeric field and make the settings for the parameter using the On-screen keyboard or the control knob.

B] For **Profile I or Profile P** a new tab will be shown on top of the screen together with a window for the settings. Here you configure your profile and press  to start the test or press **TEST** to return to the test menu.

C] For **V Logger** the voltage will be logged during charge. You can set time values for warning and stop.

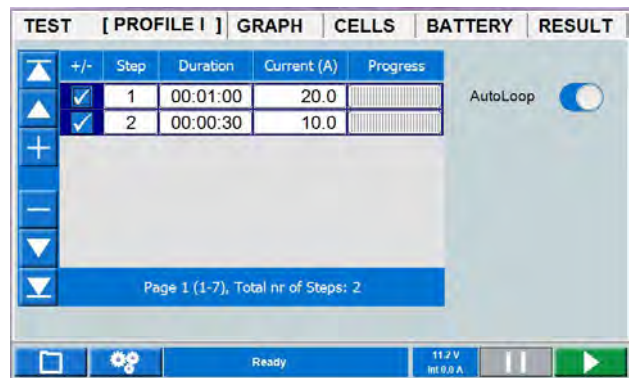

Warning and stop limit parameters

You can set TORDEL to issue a warning and/or to stop:

- When the voltage has reached a certain level.
- When a certain amount of capacity is discharged.
- After a specified time.

- When a cell voltage has reached a certain level (if BVM is used, see section "9.2 BVM - Battery Voltage Monitor" on page 35).

The warning and stop limits can be set and changed during a test.

The settings for the warning and stop levels are independent of each other.

See also chapter "7 Alarm function" on page 30

Warning limit

When a "Warning" limit is reached, the "information bar" turns yellow and the warning cause is displayed. The alarm buzzer sounds as well.

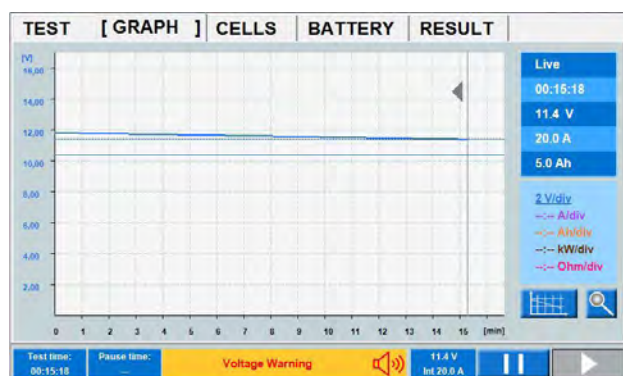

The warning is confirmed by pressing the "information bar" and the alarm buzzer stops to sound.

Stop limit

When a "Stop" criteria is reached, the "information bar" turns red and the cause of stop is displayed.

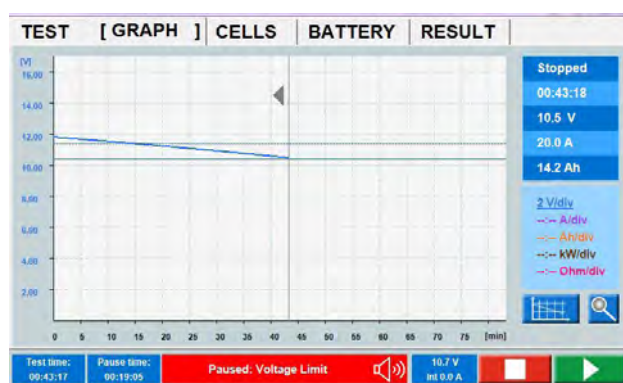

Note *This means that the discharge is stopped and you can change parameters and continue the test or press  to close the test.*

When BVM stop limit is set and a BVM gets loose during test, the test stops.

Setting the limit parameters

- 1] Press the numeric field and make the settings for the limit parameter using the On-screen keyboard or using the control knob (press to confirm).
- 2] Enable the limit by touching the checkbox.

- 3] Go on with the desired parameters.

Test configuration

- 1] Press 

ID Labels

- 2] Click the label fields and enter the information as desired.

Settings

- Select **Internal** (prefault) or **External**.
For external current clamp/current shunt set the **Ratio**, see section "6.2 Setting up external current measurement" on page 26.
- If desired enable temperature compensation.
- If desired enable cell numbering from plus (default numbering is from minus).

Temperature compensation

If temperature compensation is enabled, see above, a button  will be shown in TEST menu.

- 1] Press  to make settings for the temperature compensated test.
- 2] Press button to the right to enable **Rate** or **Time** correction.
You can select according to IEEE and IEC standards or **Manual** setting:

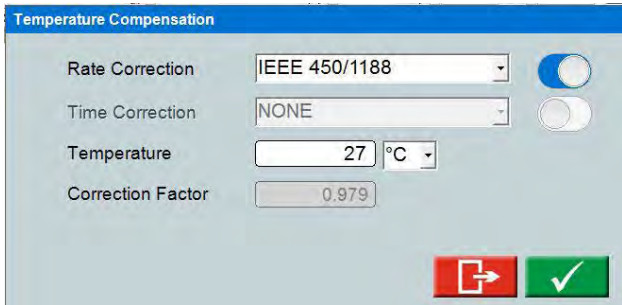

Language

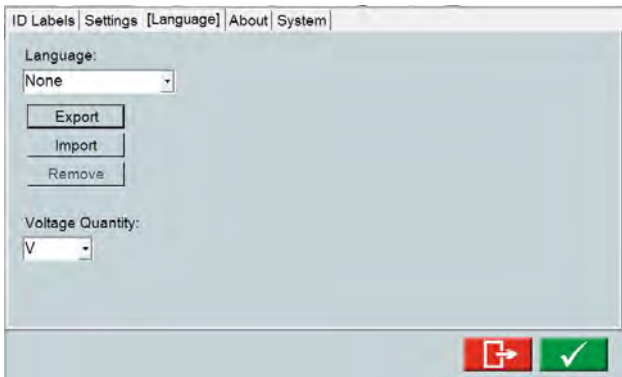

- Manage language files for the internal software and select **U** or **V** as the symbol for voltage.

About

- Information about software version etc.

System

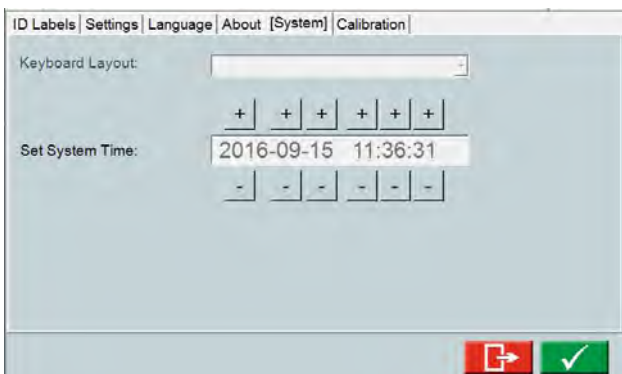





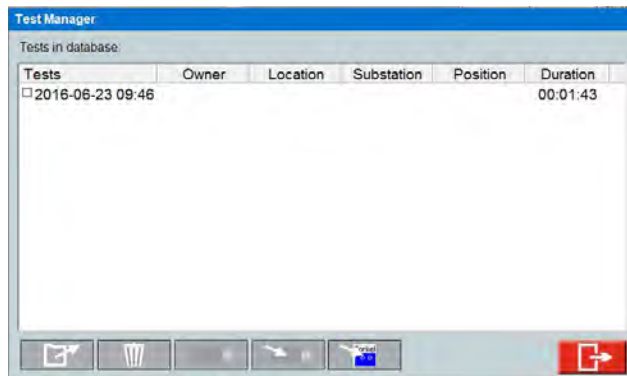

- Select external keyboard.
- Set the time

Test Manager

- 1] Press 



- 2] Select a test by marking the checkbox.
- 3] You can use the buttons at the bottom for actions described below:

	to open a test
	to put test in the trash can
	to undelete all tests
	to save test on USB stick for use in PC
	to import data from USB
	to save for use in TORTEL Win

GRAPH

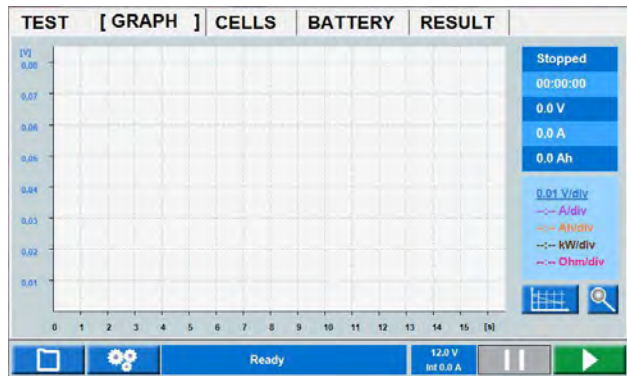

Graph settings

- 1] Press 

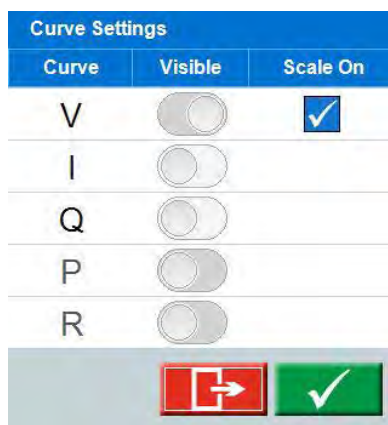

Make settings for the axis. Above is an example of a setting that will show the voltage curve.

Zoom

- 1] Press  to zoom the graph

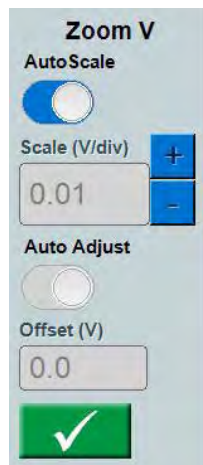

- 2] Set scale for y-axis and set the offset value or select Auto scale.

RESULT

After ending a test you can go into the different tabs to see the result.

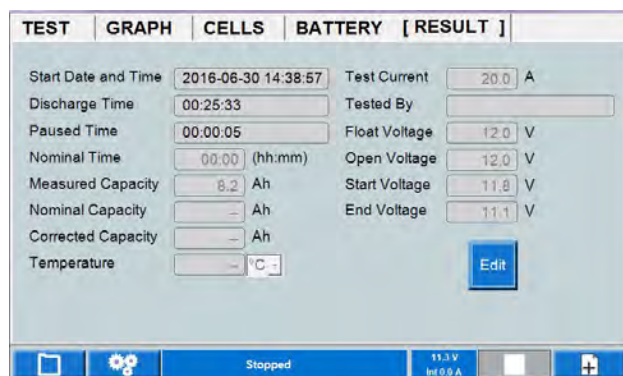

- 1] In the RESULT and BATTERY tabs you can add information by pressing the "Edit" button.

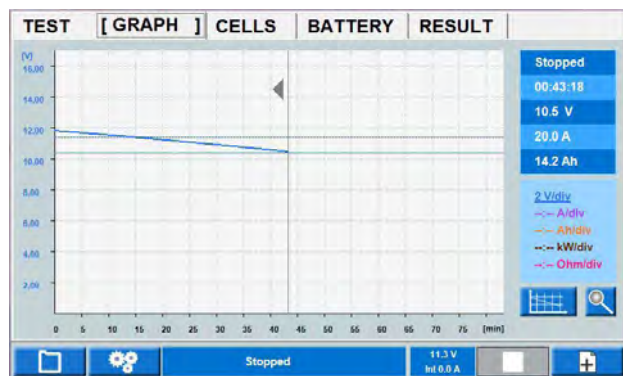

By pressing in the diagram, test data for the selected time will be shown in the table.

The specific time interval can also be examined by zooming the time axle.

- 1] Press in the diagram where you want to examine details on the voltage curve.
- 2] Press the control knob shortly and turn it clockwise to zoom. Tap on the diagram and to scroll the cursor for this time interval.
- 3] To return to the full test, press the control knob shortly and turn it counterclockwise.

REPORT

- 4] The saved tests can be stored on an USB memory stick and transferred to a PC. The included PC software TORDEL Viewer can be used to edit and print out reports. Edited reports can be transferred back to TORDEL i.e. you can design the test and settings in TORDEL Viewer.

CELLS (optional BVM)

When using the optional BVM equipment you get information of the cell voltages, see also section "9.2 BVM - Battery Voltage Monitor" on page 35.



Diagram shows voltage per cell during the test.

- The LIVE voltage means the present voltage
- The FLOAT voltage means the voltage read prior to removing the battery charger.
- The START voltage is when the discharge tests start.

- 1] By pressing a cell bar, readings can be seen in the table as the "Sel" value.

4.2 TORKEL Viewer

TORKEL Viewer is delivered together with TORKEL (not with TORKEL 910) on a USB stick

- 1] Double click the:
"TORKEL Viewer Setup.msi" file.
- 2] Follow instructions and the TORKEL Viewer will be installed on your computer.
- 3] Click  "Open data set".

Note *After installation you can find a demo file at C:\Program Files (x86)\Megger\Torkel Viewer\Reporting.*

- The "Report " tab includes several settings and options on how to set up the test report.
With the "Save test file" button a test can be prepared in advance with information of the test object.
- The "Plot" tab gives you the possibility to check the battery measurements or the BVM voltages diagram.
By right click and drag on the y-scale of resp. entity the diagram lines can be modified.
The time scale can also be adjusted by right click and drag the scale.
By placing the cursor in the diagram and scrolling with mouse, zooming of the time scale will be done.
Clicking the "Auto zoom" will reset the diagram to the default appearance.
Clicking the "Export Plot" button will export the diagram in a .png format.
- The "Preview" tab is simply a way of checking the report after modification, prior saving or print out of the report.
- The "Settings" tab includes "Chose language" and "Tools for translators".

Optional

The BVM measurements can also be examined by selecting the BVM voltage diagram in the "Choose plot to display".

The diagram can be moved by right click and drag. Each voltage cell can be checked by clicking on the cell bar. Float, start and end values are presented.

TORKEL Calc

The TORKEL Calc is an application in TORKEL Viewer used for calculating how many TORKELs and TXLs are needed. See also section "8.1 When a single TORKEL isn't enough" on page 32.

5 Making a test

5.1 Preparations for testing

WARNING
See the chapter "2.2 Safety instructions" on page 8.

- 1] Connect TOR KEL to the mains voltage.
- 2] Switch on TOR KEL.
The display will show the following after a short time:

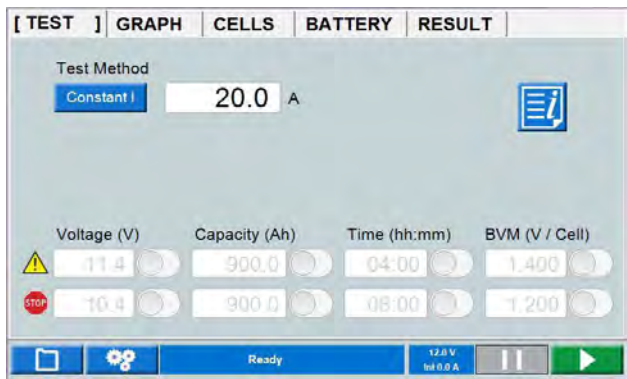

Connecting the current cables to the battery

Important
Connection and disconnection procedures are extremely important. Be sure to follow the instructions.

Use the cables supplied with TOR KEL or other cables of suitable size. Follow the numbered steps that are set forth below. Inspect each connection to make sure it is securely fitted.

- 1] Connect one end of the first cable to the negative (-) terminal on TOR KEL.
- 2] Connect the other end of the first cable to the negative (-) pole of the battery.
- 3] Connect one end of the second cable to the positive (+) pole of the battery.
- 4] Connect the other end of the second cable to the positive (+) terminal on TOR KEL.



Tip
To get a more accurate voltage reading when current cables are long and the discharge current is high. Connect the voltage sensing cables between the "VOLTAGE SENSE" input on TOR KEL and the battery terminals.

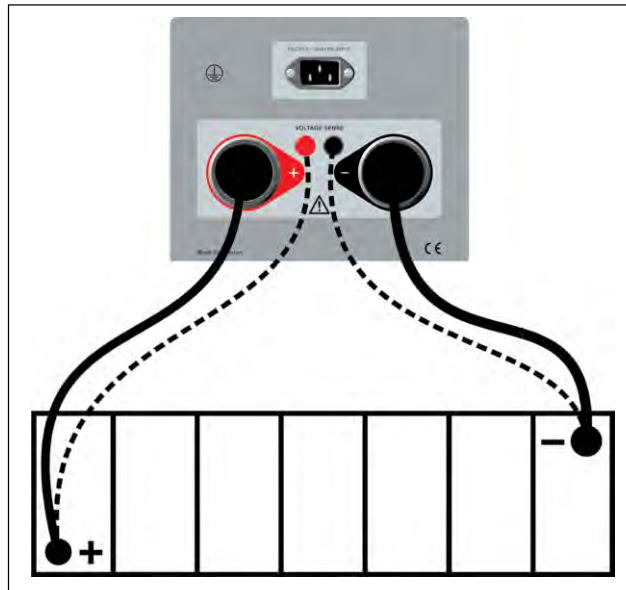

The sensing cables (dotted lines) are normally not needed.

Note TOR KEL automatically selects the voltage range when voltage is applied to the high-current terminals.

Note You can start a test in any of the menus. While test is running you can go into any tab and pause the test and make changes and continue the test.

Emergency stop button

The button is intended to be used if a fault occur in the test object and/or the external testing cables.

- 1] Press the button  to immediately interrupt discharging. TOR KEL will still have power and the cooling fans will run at maximum speed.
- 2] Reset the stop button by turning it right. If you consider it safe to continue the test you can start the test again.

5.2 Test at constant current

Preparations

Follow the safety precautions set forth in section "2.2 Safety instructions" on page 8 and the preparations for testing in section "5.1 Preparations for testing" on page 18.

Select "Test Method"

- 1] Press "Constant I"
- 2] Set the desired current by pressing the numeric field and make the settings for current using the On-screen keyboard.
- 3] Make settings for warning and stop limits, see section "Warning and stop limit parameters" on page 12.



Tip

You can change the settings for current and limits at any time in "TEST".

Starting the test

- 1] Wait for "Connected ready" to be displayed on the information bar and the control knob is lit.
- 2] Press  The current value (A) will be displayed and the control knob lamp will start blinking.

Pausing the test

- 1] Press 
- 2] Restart by pressing 

Note Any TXL Loads connected to TORHEL must be restarted manually.

Ending the test



WARNING

Do not disconnect any cables until the test is completed and stopped

- 1] Press 



- 2] Press "Yes"
- 3] Disconnect the cables in reverse order that they were connected.



WARNING

Do not connect a discharged battery to a battery that has not been discharged. The batteries must be charged to the same potential (voltage) before they are connected together.

For viewing results and report see section "5.7 Viewing results and reporting" on page 24.

5.3 Test at constant power

TORHEL can be used to conduct a discharge test at constant power instead of constant current. All procedures are the same except that you must set TORHEL differently before starting – you set the power instead of the current.

Preparations

Follow the safety precautions set forth in section "2.2 Safety instructions" on page 8 and the preparations for testing in section "5.1 Preparations for testing" on page 18.

Configuring TORHEL for constant power

- 1] Calculate the current at the end of the test (divide the power by the voltage).
- 2] Then make sure that the total current does not exceed 2999 A and that the TORHEL and TXL units can load with the required current throughout the test.

Select "Test Method"

- 1] Press "Constant P"
- 2] Set the desired Power by pressing the numeric field and make the settings for power using the On-screen keyboard.
- 3] Make settings for warning and stop limits, see section "Warning and stop limit parameters" on page 12.



Tip

You can change the settings for power and limits at any time in "TEST".

Starting the test

- 4] Press  The power value (kW) will be displayed and the control knob lamp will blink.

Pausing the test

- 1] Press 
- 2] Restart by pressing 

Note Any TXL Loads connected to TORHEL must be restarted manually.

Ending the test



WARNING

Do not disconnect any cables until the test is completed and stopped

- 1] Press 



- 2] Press "Yes"
- 3] Disconnect the cables in reverse order as described in section "Connecting the current cables to the battery" on page 18



WARNING

Do not connect a discharged battery to a battery that has not been discharged. The batteries must be charged to the same potential (voltage) before they are connected together.

For viewing results and report see section "5.7 Viewing results and reporting" on page 24.

5.4 Test at constant resistance

TORKEL can be used to conduct a discharge test at constant resistance instead of constant current. All procedures are the same except that you must set TORKEL differently before starting – you set the resistance instead of the current.

Preparations

Follow the safety precautions set forth in section "2.2 Safety instructions" on page 8 and the preparations for testing in section "5.1 Preparations for testing" on page 18.

Select "Test Method"

- 1] Press "Constant R"
- 2] Set the desired Resistance by pressing the numeric field and make the settings for resistance using the On-screen keyboard.
- 3] Make settings for warning and stop limits, see section "Warning and stop limit parameters" on page 12.



Tip

You can change the settings for resistance and limits at any time in "TEST".

Starting the test

- 4] Press  The resistance value (Ohm) will be displayed and the control knob lamp will blink.

Pausing the test

- 1] Press 
- 2] Restart by pressing 

Note *Any TXL Loads connected to TORKEL must be restarted manually.*

Ending the test



WARNING

Do not disconnect any cables until the test is completed and stopped

- 1] Press 



- 2] Press "Yes"
- 3] Disconnect the cables in reverse order as described in section "Connecting the current cables to the battery" on page 18



WARNING

Do not connect a discharged battery to a battery that has not been discharged. The batteries must be charged to the same potential (voltage) before they are connected together.

For viewing results and report see section "5.7 Viewing results and reporting" on page 24.

5.5 Testing with a load profile

TORKEL can be used to conduct a test that incorporates a current profile or power profile. A profile can consist of up to 25 time intervals. The duration and the magnitude of the load can be specified for each interval.

If you want step or steps to be repeated you enable the "Auto Loop".

Note *Using more than 20 steps will slow the system.*

Preparations

Follow the safety precautions set forth in section "2.2 Safety instructions" on page 8 and the preparations for testing in section "5.1 Preparations for testing" on page 18.

Select "Test Method"

- 1] Press "Profile I" or "Profile P"

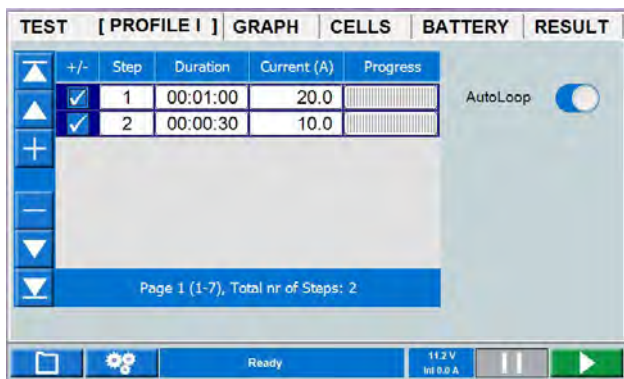

- 2] Set the desired "Duration" by pressing the numeric field and make the settings for duration using the On-screen keyboard.
- 3] Set the desired current or power by pressing the numeric field and make the settings for current using the On-screen keyboard.
- 4] Make settings for warning and stop limits, see section "Warning and stop limit parameters" on page 12.



Tip *You can change the settings for current/power and limits at any time in "TEST".*

Starting the test

- 5] Press The current value (A) or power (kW) will be displayed and the control knob lamp will blink.

Pausing the test

- 1] Press
- 2] Restart by pressing

Note *Any TXL Loads connected to TORKEL must be restarted manually.*

Ending the test



WARNING Do not disconnect any cables until the test is completed and stopped.

- 1] Press



- 2] Press "Yes".
- 3] Disconnect the cables in reverse order as described in section "Connecting the current cables to the battery" on page 18



WARNING Do not connect a discharged battery to a battery that has not been discharged. The batteries must be charged to the same potential (voltage) before they are connected together.



Tip *You can select to make the charging test immediately after a discharging test and keep all connection as they are.*

For viewing results and report see section "5.7 Viewing results and reporting" on page 24.

5.6 V Logger

TORKEL can log the voltage during charging of the batteries.

Starting "V Logger" directly after a discharge test



Tip

You can select to make the charging test immediately after a discharging test and keep all connection as they are.

- 1] Press "Save and start V logger". This will be a separate new test.
- 2] Press 
- 3] Start charging the batteries.
- 4] You can change the Warning and Stop limits during the test.

Starting "V Logger" as a separate test

Preparations

Follow the safety precautions set forth in section "2.2 Safety instructions" on page 8 and the preparations for testing in section "5.1 Preparations for testing" on page 18.

Select "Test Method"

- 1] Press "V Logger" button.
- 2] Make settings for warning and stop time, see section "Warning and stop limit parameters" on page 12.
- 3] Press 
- 4] Start charging the batteries.

Ending the test



WARNING

Do not disconnect any cables until the test is completed and stopped.

- 1] Press 



- 2] Press "Yes".

- 3] Disconnect the cables in reverse order as described in section "Connecting the current cables to the battery" on page 18



WARNING

Do not connect a discharged battery to a battery that has not been discharged. The batteries must be charged to the same potential (voltage) before they are connected together.

5.7 Viewing results and reporting

Viewing the results

- 1] Select the "RESULT" tab to view the test results
- 2] In the RESULT and BATTERY tabs you can add information by pressing the "Edit" button.

Float voltage	The voltage value prior the charger is removed.
Open voltage	The value prior start of discharge test.
Start voltage	The value given after the first initial decrease of the battery bank at a start of a discharge test.
End voltage	The value at the end of discharge test

REPORT

The saved test can be stored on an USB memory stick and transferred to a PC. The included PC software TORHEL Viewer can be used to edit and print out reports, see page "4.2 TORHEL Viewer" on page 16

6 External current measurement

6.1 General

External current measurement must be used when:

- TOR KEL is working together with TXL Loads.
- Testing without disconnecting the regular load.
Since total current is measured, TOR KEL can compensate for changes attributable to the regular load. The total current from the battery is then kept at a constant value. This ensures accurate test results.

The external current measurement function enables TOR KEL to measure the total current in an external path and base regulation on this measurement.

A DC clamp-on-probe (optional accessory) has to be used for this measurement. It can be applied at one of the battery terminals or at an inter-cell connector. The clamp-on-probe must measure the total current, including that which passes through TOR KEL.

A current shunt can also be used, but this requires opening the current path and connecting the shunt in series. The current shunt must be connected to the negative side of the battery.

 **WARNING**
External current shunt may not be used above 300 V DC

 **Important**
Always activate the warning and stop limit functions when using external current measurement. This will protect your batteries if the DC clamp-on-probe will malfunction.

 **Important**
If a current shunt is used it must be connected on the negative side of the battery.

 **Tip**
For tests where it is important to obtain the desired current within a few seconds or less it is better to use internal current measurement since it provides faster regulation.

6.2 Setting up external current measurement

 **WARNING**
See the chapter "2.2 Safety instructions" on page 8.

DC clamp-on-probe

Preparation and requirements of the clamp-on-probe to be used.

- The clamp-on-probe output voltage must not exceed 1 V.
- Make sure that the clamp-on-probe has fresh batteries. The batteries must last throughout the entire test.
- The clamp-on-probe must be accurate and calibrated and it must be able to carry a load of 600 kΩ. Please note that a clamp-on-probe is usually less accurate in the lowest part of its measurement range.

Resetting the output voltage

- 1] Place the clamp-on-probe as far as possible from any magnetic field
- 2] Connect a DC voltmeter (set to 2 V full scale) to the clamp-on-probe.
- 3] Switch on the clamp-on-probe and adjust its zero knob to set the output to 0.0 V

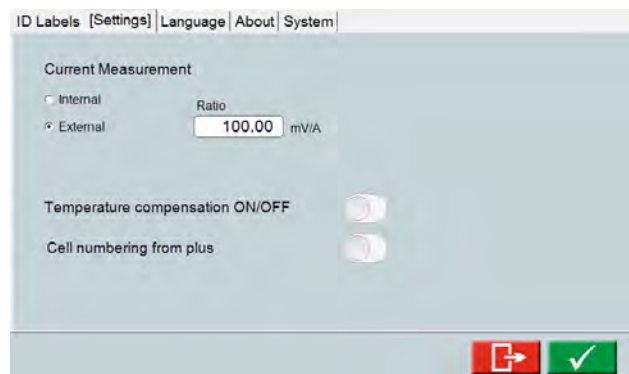

The mV/A ratio for the input can be set to a value between 0.1 mV/A and 100 mV/A.

- 1] In "TEST" press 
- 2] Press "Settings".
- 3] Select "External" for "Current measurement".

- 4] Press the numeric field to set the "Ratio" for the current clamp to be used.
- 5] Press 
- 6] Activate the warning and stop limit functions.
- 7] Connect the clamp-on-probe to input $I_{EXT} \leq 1V$. Best results are obtained if the cables running from the clamp-on-probe are twisted.

Note *If the clamp-on-probe has an adapter for using external power supply. Use the power supply from TOR KEL (DC Out) connector, that gives 9 V.*



Important

The clamp-on-probe must always be applied in such a way that current through TOR KEL is included in the measurement.

- 8] Apply the clamp-on-probe to the conductor.
- 9] Turn on the power switch on the clamp-on-probe.
- 10] Make the setup for preferred test mode.

Troubleshooting

- 1] Check that the clamp-on-probe is properly connected to TOR KEL.
- 2] Check that the clamp-on-probe is switched on.
- 3] Check that the clamp-on-probe has fresh batteries.
- 4] Check the following settings in "TEST SETTINGS", "Settings":
 - "I measurement" must be set to "External".
 - The mV/A ratio must match the ratio that appears on the clamp-on-probe itself.

6.3 Applications

TOR KEL used together with TXL Extra Load

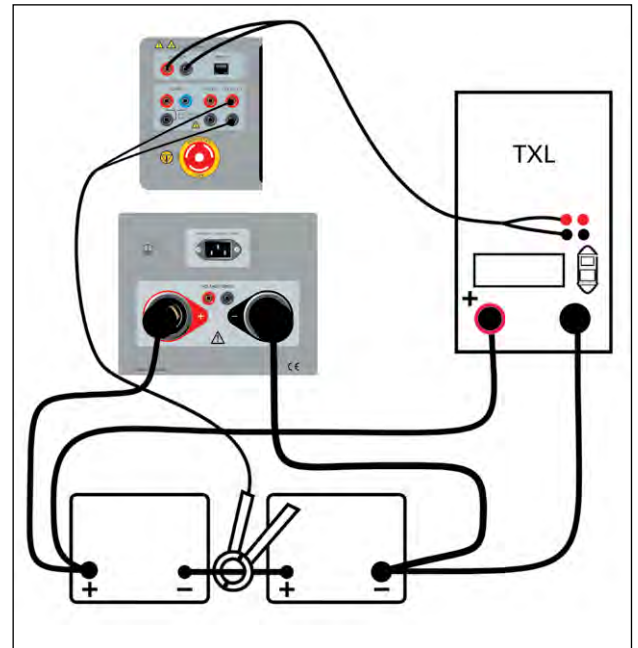

A current shunt can also be used, but this requires opening the current path and connecting the shunt in series.

Multiple units used together

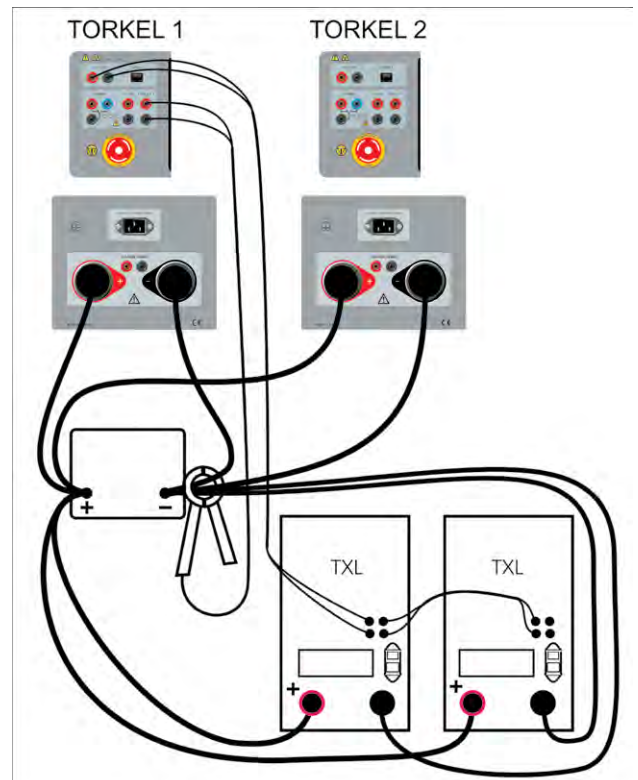

The first TOR KEL regulate the TXLs.

- 1] Apply the clamp-on-probes as illustrated above.

- 2] Set the desired total current on TORDEL No. 1.
- 3] Set max current on TORDEL No. 2.
- 4] Set warning limits only on TORDEL No. 1.
- 5] Set the stop limits. The voltage and test period (time) can be set on each individual TORDEL. Stopping after a certain capacity (Ah) is reached can only be activated on TORDEL No. 1.

Note *Only TORDEL No. 1 is to control the TXLs.*

- 6] Set switch <F1> to the upper (ON) position on the TXLs.
- 7] Then start the TORDEL that has the highest number (when numbered as set forth above). Now start the TORDEL with the second highest number, then the third highest, etc. Finally, start TORDEL No. 1. Starting the TORDELS in this order prevents the current from being higher than desired at the beginning of the test.

- Sensing leads, 2 x 5 m (16 ft), used to measure voltage at the battery terminals.

Optional Clamp-on DC ammeter

- 200 A clamp-on DC ammeter
- 1000 A clamp-on DC ammeter

Note *TORDEL has an output for power supply to a Clamp-on DC ammeter.*

Constant current, regular load connected

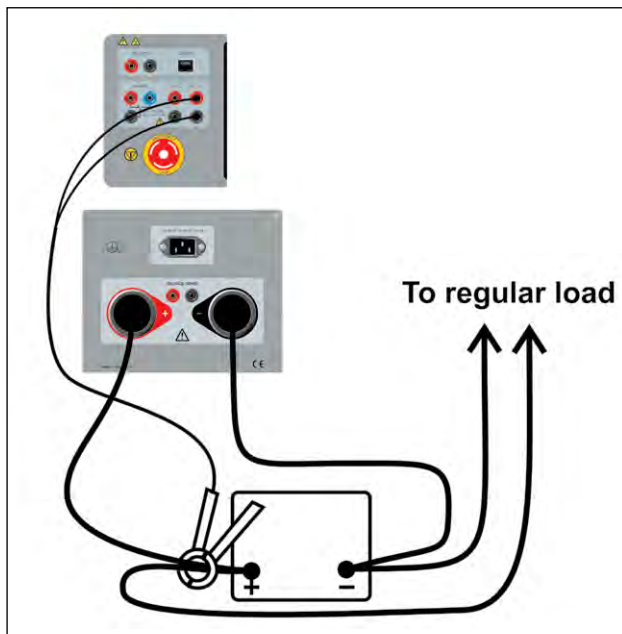

A current shunt can also be used, but this requires opening the current path and connecting the shunt in series.

Battery cables

- Cable set, 2 x 3 m (10 ft), 70 mm² for connecting TORDEL to the battery

Optional cables

- Cables for controlling a TXL Extra Load from TORDEL.

7 Alarm function

7.1 Description

The TORKEL alarm function is provided by a buzzer and a relay connected to the <ALARM> - connector. An external alarm device can be connected to this connector if desired.

Devices higher than Cat II must not be attached to the alarm connector.

Relay contact

8 A / 28 V DC

0.28 A / 250 V DC (resistive load only)

8 A / 240 V AC

Connector insulation

Voltage to ground must not exceed 250 V.

The following events can cause an alarm to be issued

- Warning level is passed.
- Discharging is stopped because a stop level is reached.
- TORKEL can not regulate the current to the desired level.
- Thermal protection device trips or a fan does not rotate as expected.
- The connection to the battery is broken.
- Other fault situations such as battery voltage too high or too low or excessive current through TORKEL.

Note *TORKEL will safely interrupt the discharge and issue an alarm if any of the internal temperatures should exceed the safe operating limits.*

Resetting the alarm

- 1] You can reset the alarm by pressing the information bar.

8

How to obtain the desired current

8.1 When a single TORKEL isn't enough

TORKEL regulates current by lowering its internal resistance as the voltage drops. However, the resistance elements built into TORKEL impose a limit beneath which further lowering is impossible.

- You must make some simple calculations before starting a test to find out whether or not TORKEL will be able to provide the desired load current.
- You must also make certain that TORKEL will be able to sustain this current until the test ends.

When a single TORKEL cannot provide the current you need, you can:

- Connect one or more TXL Extra Loads to TORKEL.
- Connect two or more TORKELS in parallel.
- Connect two or more TORKELS and two or more TXL Extra Loads into a single system.

When two or more TORKELS are connected into a single system, you will normally use the "External current measurement" function.

TXL Extra Loads connected to TORKEL

TXLs are resistive loads which are unable to provide any sort of regulation. Regulation is provided by TORKEL which measures the total current and keeps it constant. See the chapter headed "External current measurement" which shows how to connect the TXL(s) and TORKEL(s).

When TXL Extra Loads are connected to TORKEL, you must check:

- That the current flowing through the TXLs when the test is started is not higher than intended.
- That TORKEL has enough regulation capability a) to compensate for the drop in current through the TXLs at the end of the test and b) to set the current to the correct value at the beginning of the test.

Calculating how many TORKELS and TXLs are needed



Tip

You can use the TORKEL Calc application in the TORKEL Viewer for making the calculation (not included with TORKEL 910). See "4.2 TORKEL Viewer" on page 16.

1. Number of TXLs – Current flowing through TXL(s) at beginning of a test

At the beginning of the test, as high a percentage as possible of the current must flow through the TXLs, thereby providing the TORKEL(s) with as much reserve regulation capability as possible. However, the current through the TXLs must not, of course, exceed, the desired current value (A).



Tip

Remember that the internal resistances of the TXLs can be set manually. For accurate calculation, add the cable resistance to the internal resistance.

- The current in an individual TXL can be obtained by dividing the voltage at the beginning of the test by the internal resistance of the TXL in question (see tables below).
- Calculate the number of TXLs that you can connect without exceeding the desired total current.

2. Current flowing through TXL(s) at final voltage

- Multiply the total current through the TXL(s) which you obtained in step 1 above by the final voltage, and then divide by the voltage at the beginning of the test.

3. Number of TORKELS – for the current regulation

The TORKEL or TORKELS in the system must regulate the current to the desired value and compensate for the drop in current through the TXL(s) that occurs at the final voltage.

- The amount of regulation needed can be obtained by subtracting the current value (A) obtained in step 2 above from the desired current.
- Calculate the number of TORKELS required for the current regulation.

4. Are all of the TXLs needed?

If the total load-providing capability of the TORKEl(s) exceeds the amount of regulation needed by a wide margin (as set forth in step 3 above), you can perhaps conduct the test with fewer TXLs. If this margin is wider than the current through one of the TXLs at the final voltage, this TXL is not needed.

Note *Discharge is from 2.15 V to 1.8 V per cell*

TORKEl 930

Systems TORKEl 930 and TXL 830 (Pos 3)		
12V battery (6 cells)		
Max constant current (A)	No. of TORKEl 930	No. of TXL 830
183	1	1
299	1	2
414	1	3
24V battery (12 cells)		
Max constant current (A)	No. of TORKEl 930	No. of TXL 830
384	1	1
615	1	2
846	1	3

Systems TORKEl 930 and TXL 850 (Pos 3)		
48 V battery (24 cells)		
Max constant current (A)	No. of TORKEl 930	No. of TXL 850
452	1	1
685	1	2
918	1	3
1151	1	4

Systems TORKEl 930 and TXL 870 (Pos 3)		
110 V battery (54 cells)		
Max constant current (A)	No. of TORKEl 930	No. of TXL 870
225	1	1
314	1	2
392	1	3
470	1	4
628	2	4

Systems TORKEl 930 and TXL 870 (Pos 1)		
220 V battery (108 cells)		
Max constant current (A)	No. of TORKEl 930	No. of TXL 870
112	1	1
156	1	2
195	1	3
235	1	4
313	2	4

TORKEl 910

Systems TORKEl 910 and TXL 830 (Pos 2)		
12 V battery (6 cells)		
Max constant current(A)	No. of TORKEl 910	No. of TXL 830
144	1	1
221	1	2
298	1	3
376	1	4
443	2	4
24 V battery (12 cells)		
Max constant current(A)	No. of TORKEl 910	No. of TXL 830
264	1	1
419	1	2
574	1	3

Systems TORKEl 910 and TXL 850 (Pos 3)		
48 V battery (24 cells)		
Max constant current(A)	No. of TORKEl 910	No. of TXL 850
342	1	1
575	1	2

Systems TORKEl 910 and TXL 870 (Pos 3)		
110 V battery (54 cells)		
Max constant current(A)	No. of TORKEl 910	No. of TXL 870
188	1	1
266	1	2
344	1	3
422	1	4
532	2	4

Systems TORKEl 910 and TXL 870 (Pos 1)		
220 V battery (108 cells)		
Max constant current(A)	No. of TORKEl 910	No. of TXL 870
112	1	1
156	1	2
195	1	3
235	1	4
313	2	4

9 Optional equipment

9.1 TXL830/850/870/890 (Extra Loads)

The TXL830, TXL850, TXL870 and TXL890 Extra Loads comprise resistive loads. They can be used together with TORKEL Load Units to increase loading capability. The TXL Extra Loads can not provide regulation by themselves but TORKEL measures total current from the battery and regulates the load characteristic. When TORKEL is stopped it sends a stop signal to the TXL Extra Load.

The four models have different maximum voltage ratings:

- TXL830 28 V
- TXL850 56 V
- TXL870 280 V
- TXL890 480 V

Panel

The panels for the four TXL models differ somewhat but the functionality is the same.



1. Selector switch
Switch used to set the desired voltage range and/or resistance value.
⚠ WARNING
Do not exceed maximum voltage.

2. Control
CONTROL IN
Input for control signal from TORKEL-unit. Galvanically isolated.
CONTROL OUT
Output used for the control signal sent from TORKEL to the adjacent TXL-unit. Galvanically isolated.

3. Circuit breaker
F1
Voltage-controlled circuit breaker that connects the resistors in the TXL Extra Load to the battery.
Note F1 will not latch or remain at upper (ON) position unless the mains switch is turned on and a control signal from TORKEL is present at the "CONTROL IN" input..
⚠ WARNING
The circuit breaker F1 is an important component in the safety system. If the temperature will be too high and/or the cooling fans malfunction, the F1 will trip. It is important to never operate the unit if there is any damage or malfunction to the circuit breaker or if any damage or malfunction is suspected.

4. Mains inlet
MAINS
Connector used for mains supply, equipped with ON/OFF switch.

5. Connection terminals for the battery
+ (Terminal)
Positive (+) current connection for battery or other DC source, being tested.
- (Terminal)
Negative (-) current connection for battery or other DC source, being tested.
Insulation voltage to ground: 2200 V

Using the TXL

When an extra load is to be used, you must use the external current measurement function (see the chapter headed "6 External current measurement" on page 26).

- 1] Set the range selector switch to the desired position.
- 2] Connect as shown below.

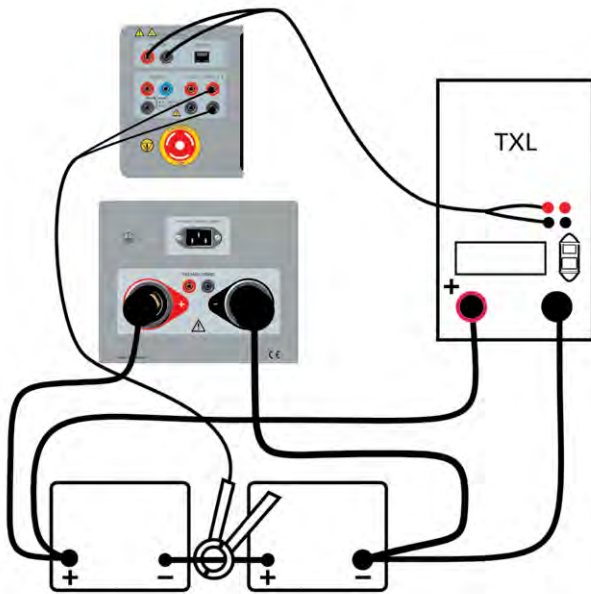

- 3] Connect the control wires between the TXL CTRL output on TORTEL and the CONTROL IN input on the TXL.
If two or more TXLs are to be used, provide a connection between the CONTROL OUT output on the first TXL and the CONTROL IN input on the second TXL, etc.
- 4] Connect the TXL to the mains voltage
- 5] Switch on the TXL.

Testing



WARNING

See the chapter "2.2 Safety instructions" on page 8. for safety precautions.

- 1] Proceed in the same way as set forth in the chapter headed "5.1 Preparations for testing" on page 18 but before you start TORTEL you must set switch F1 to upper (ON) position on the TXL. (You must do this manually.)
- 2] Start TORTEL by pressing 
- 3] When TORTEL is stopped, manually or by any stop condition, the TXL will also shut off the discharge current.

9.2 BVM - Battery Voltage Monitor

The BVM (Battery Voltage Monitor) is a battery voltage measurement device that is used for monitoring of cell voltages and battery blocks in battery banks commonly found in electrical power sub-stations, telecom facilities and computer data center UPS systems. In conjunction the TORTEL unit, and test data management software, such as PowerDB or TORTEL Win, the BVM enables a completely automated battery bank capacity test to be performed.

BVM is available in three kits:

- BVM150 with 16 BVM units
- BVM300 with 31 BVM units
- BVM600 with 61 BVM units



1. Control cable – Output socket
2. Control cable – Input socket
3. Battery sense – Dolphin clip

The BVM is designed in modular form where one BVM device is used for each battery or "jar" in the string to be tested. It measures the voltage for each battery cell and each unit can handle up to 20 V. The BVMs connects to the batteries in a "daisy-chain" fashion, thereby providing easy and economical expandability to meet the testing requirements for small-to-large battery bank systems. Up to 240 BVMs can be daisy-chained in a single battery bank under test.

The included dolphin-style battery clamp can be easily removed and exchanged with different styles of standard banana plug clamps and/or extension cables to accommodate any battery connection requirement.

There is an Activity LED on the BVM that flashes whenever an individual BVM transmits data back to the data acquisition host computer. This LED activity is useful for indicating that the device is functioning properly.



The other parts of the BVM system: AC Adapter, Power and Signal Connector and cables.

Power & signal connector unit

The BVM units require external 24 DC power and RS-485 data communications for operation. These functions are provided by a combination of an external DC power supply and a Power & signal connector unit. The Power & signal connector conversion is performed within a single moulded plug that connects directly to the laptop computer or other data acquisition device. The Power & signal connector has an RJ-45 connector that provides a connection to the first BVM unit in the chain, and this connection provides RS-485 data and power to all BVM units in the BVM string.

Test setup



WARNING

See the chapter "Safety" for safety precautions.

Battery string voltage max 300 V when the BVM loops are connected to TORQUEL 900.

Battery string voltage max 600 V when the BVM loops are connected via opto coupler to a laptop/PC.

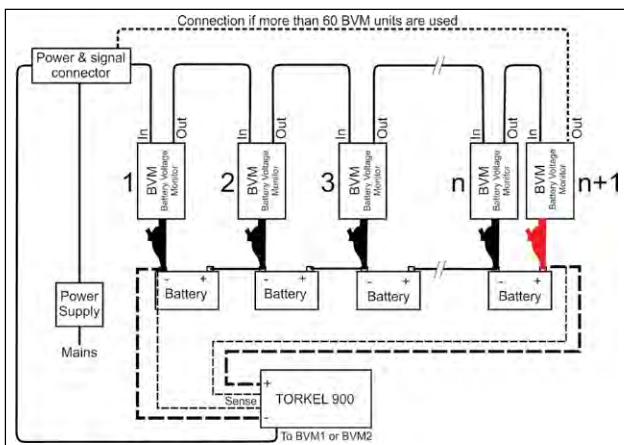

The BVM must always be connected from minus to plus. The last dolphin clip in the chain (red) shall be connected to the positive battery pole of the last battery in the bank.

- 1] Connect the BVM units as shown in the connection diagram, see below. Each BVM is identical and can be connected in any battery test position. Up to 120 BVMs can be daisy-chained in a single battery bank under test. If you need more than 120 BVMs they must be connected in two loops, see connection diagram next page.

Note The BVM must always be connected from minus to plus. The last dolphin clip in the chain (red) should be connected to the positive battery pole of the last battery in the bank. If more than 60 BVM units are connected an extra cable is needed. See connection diagram.



Warning

A BVM control cable must never be connected directly to a computer network inlet.

- 2] **A. Battery string voltage max 300 V**
Connect the cable from "Power & signal connector" to BVM1 / BVM2 terminals on TORQUEL 900.
B. Battery string voltage max 600 V
Connect the cable from "Power & signal connector" to Opto Coupler (UH401-2kV).
- 3] **A. Battery string voltage max 300 V**
Connect to a grounded Power Supply
B. Battery string voltage max 600 V
Connect to an ungrounded Power Supply



Warning

Do not use any other Power Supply than the original delivered together with BVM.

- 4] Start TORQUEL 900

The BVM "Auto Discovery" feature enables the host device to automatically determine the number of batteries under test and provide sequential identification of each BVM in the test string.

The initialization time for the BVMs depends on how many BVMs are connected. E.g. with 2 loops and 240 BVMs, it is about 3 to 4 minutes. With 1 loop and 12 BVMs, some seconds.

The connected cells are shown under tab "CELLS".

Loose BVM unit detection

If BVM unit 1 comes loose during test, the first bar in the bar graph indicates and a beep sounds.

If the BVM unit between 2 and 3 cell becomes loose, the staple bars for cell 2 and 3 indicates.

If the last BVM unit is loose, the last staple in the staple bar diagram indicates.

Optional BVM equipment

BVM Cal Kit

Calibration system for BVM units.

Instructions for calibration included with the BVM Cal Kit.



Extension cables

The BVM cables (USB) may be extended 2 x 5 m with an Opto Coupler (e.g. B&B UH401 2kV) in between.



Note "Active" USB cables does not work.

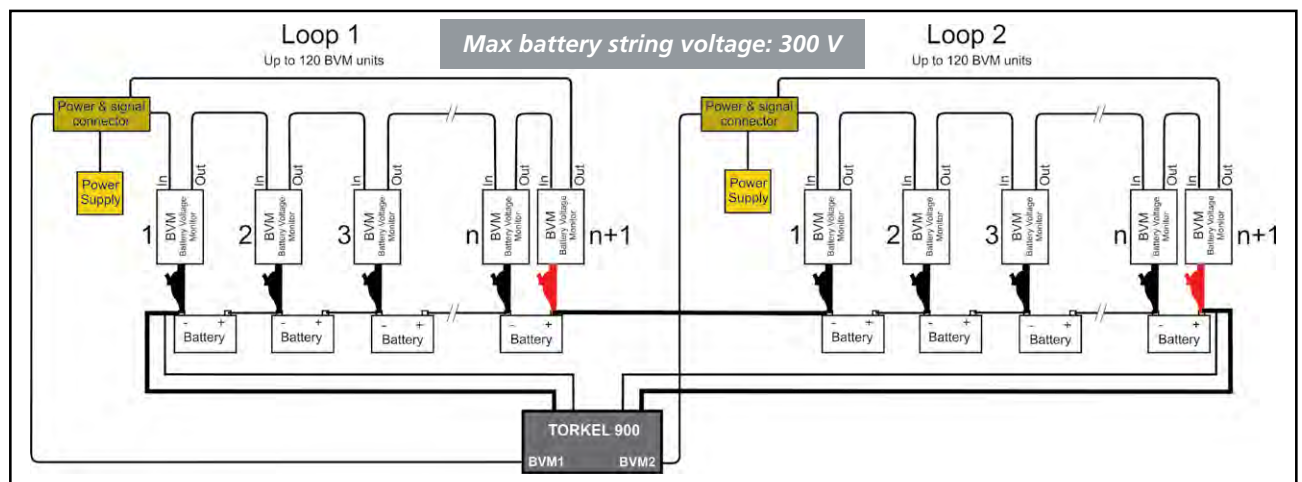

When the battery bank exceeds 120 cells, this connection with 2 BVM loops shall be used.

Connect the first loop to the BVM1 connector on TORTEL and the second loop to the BVM2 connector on TORTEL.

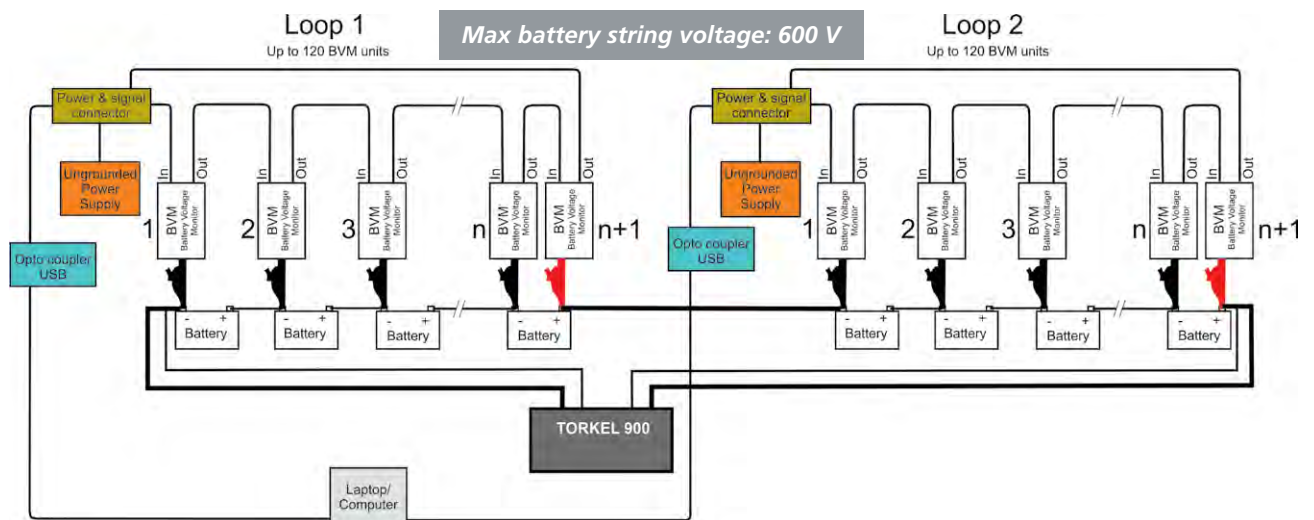

The connection shown above must be used when the battery bank voltage exceeds 300 V. It includes two opto couplers and two ungrounded power supplies. The loops must be connected to a laptop/computer.

10 Troubleshooting

Problem	Cause	Remedy
BVM connected to TORHEL		
BVM does not get initialized	Problem with the connection to BVM port	<ol style="list-style-type: none"> 1. Check/verify BVM connector on TORHEL
Communication lost with BVM units	Cable/power fault	<ol style="list-style-type: none"> 1. Check cables, BVM units and Power supply to the BVM units. 2. Check/replace the Power & Signal converter. 3. If more than 60 BVM units connected, extra cable needed. See the connection diagram.

11 Specifications

TORKEL 900-series

Specifications are valid at nominal input voltage and an ambient temperature of +25°C, (77°F). Specifications are subject to change without notice.

Environment

Application field The instrument is intended for use in high-voltage substations and industrial environments.

Temperature

Operating 0°C to +50°C (32°F to +122°F)
Power derating at temperatures over +35°C (+95°F)

Storage & transport -40°C to +70°C (-40°F to +158°F)

Humidity 5% – 95% RH, non-condensing

Shock/Vibration/Fall

Instrument only ETSI EN 300 019-2-7 class 7M2

Instrument in transport case ISTA 2A

Altitude

Operating 3000 m (10000 ft)

Storage 10000 m (33000 ft)

Encapsulation class IP20

CE-marking

LVD IEC61010-1:2010 & IEC61010-2-030

EMC IEC61326-1

General

Mains voltage 100 – 240 V AC, 50/60 Hz

Power consumption 200 W (max)

Power interruption 40 ms (max)

Protection Thermal cut-outs, Automatic overload protection, Emergency stop button

Dimensions 519x315x375 mm, (20.5" x 12.4" x 14.7")

Weight 19.5 kg (43.0 lbs)

Display 7" LCD, Capacitive touch screen

Available languages English, French, German, Spanish, Swedish

Measurement section

Current measurement

Display range 0.0 to 2999.0 A

Basic inaccuracy ±(0.5% of reading +0.1 A)

Resolution 0.1 A

Internal current measurement

Range

TORKEL 910 0 to 110 A

TORKEL 930 0 to 220 A

Input for clamp-on-probe

Range 0 to 1000 mV DC

mV/A-ratio 0.30 mV/A to 100.00 mV/A

Input impedance >1 MΩ

Voltage measurement

Voltage 0 to 300 V DC

Inaccuracy ±(0.5% of reading +0.1 V DC)

Resolution 0.1 V

Sample rate 10 Hz, Values are saved when change is >10 mV

Time measurement

Inaccuracy ±0.1% of reading ±1 digit

Load section

Battery voltage 7.5 V to 300 V

Power 15 kW (max)

Load patterns Constant current, constant power, constant resistance, current or power profile

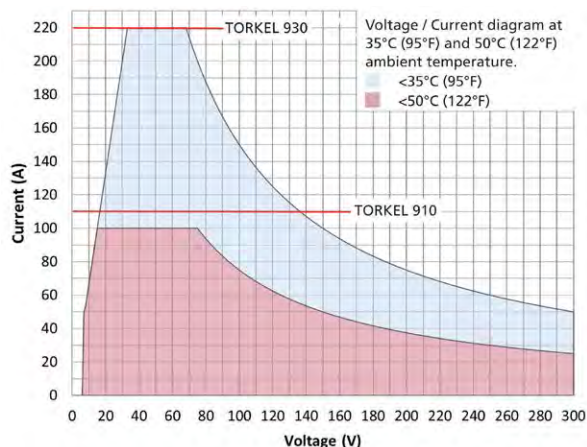

Maximal current at common battery voltages

Voltage	TORKEL 910	TORKEL 930
48 V	110 A	220 A
110 V	110 A	136 A
220 V	68 A	68 A

Constant I

Range

TORKEL 910 0 to 110.0 A

TORKEL 930 0 to 220.0 A

Inaccuracy ±(0.5% +0.2 A)

Resolution 0.1 A

Ripple ±0.4 A

Constant R

Range 300 mΩ to 3 kΩ

Inaccuracy ±0.5%

Resolution 100 mΩ

Constant P

Range 0 to 15 kW

Inaccuracy ±1% + 50 W

Resolution 10 W

Ripple ±200 W

Inputs

+ 300 V

- 0 V

I EXT ≤ 1 V 1 V DC, 300 V DC to ground

VOLTAGE SENSE Impedance to the current terminals is >1 MΩ

Outputs

ALARM

Relay contact 28 V DC, 8 A, 240 V AC, 8 A
Devices higher than Cat II must not be attached

TXL STOP

Relay contact 250VDC, 0.28A, 28VDC, 8A, 250VAC, 8A

9 V DC

9 V DC, 100 mA

Communication ports

BVM1 and BVM2 USB connection for BVM units

USB USB connection for USB memory

SERVICE For service of the instrument

TXL830/850/870/890

Specifications are valid at nominal input voltage and an ambient temperature of +25°C, (77°F). Specifications are subject to change without notice.

Environment

Application field The instrument is intended for use in high-voltage substations and industrial environments.

Temperature

Operating 0°C to +40°C (32°F to +104°F)

Storage & transport -40°C to +70°C (-40°F to +158°F)

Humidity 5% – 95% RH, non-condensing

CE-marking

LVD 2006/95/EC

EMC 2004/108/EC

General

Mains voltage 100 – 240 V AC, 50/60 Hz

Power consumption 75 W (*max*)

Protection Thermal cut-outs, automatic overload protection

Dimensions

Instrument 210 x 353 x 600 mm (8.3" x 13.9" x 23.6")

Transport case 265 x 460 x 750 mm (10.4" x 18.1" x 29.5")

Weight 13 kg (29 lbs) 21.4 kg (47 lbs) with transport case

Cable sets

for TXL830/850 2 x 3 m (9.8 ft), 70 mm², 270 A, with cable lug. Max. 100 V. 5 kg (11 lbs)

for TXL870/890 2 x 3 m (9.8 ft), 25 mm², 110 A, with cable clamp/lug. Max. 480 V. 3 kg (6.6 lbs)

Load section

	TXL830	TXL850	TXL870	TXL890
Voltage (DC) max.	28 V	56 V	140/280 V	230/480 V
Current max.	300 A	300 A	112 A at 140 V 56 A at 280 V	63 A at 230 V 32 A at 480 V
Power max.	8.3 kW	16.4 kW	15.8 kW	15.4 kW

Internal resistance, 3-position selector

Position 1	TXL830	TXL850	TXL870	TXL890
Current	0.275 Ω	0.55 Ω	4.95 Ω	14.10 Ω
100 A	at 27.6 V (12 x 2.3 V)	at 55.2 V (24 x 2.3 V)	–	–
78.5 A	at 21.6 V (12 x 1.8 V)	at 43.2 V (24 x 1.8 V)	–	–
50.1 A	–	–	at 248.4 V (108x2.3V)	–
39.2 A	–	–	at 194.4 V (108x1.8V)	–
32.3 A	–	–	–	at 469.2 V (204x2.3 V)
26.0 A	–	–	–	at 367.2 V (204 x 1.8 V)
Position 2	TXL830	TXL850	TXL870	TXL890
Current	0.138 Ω	0.275 Ω	2.48 Ω	7.05 Ω
200 A	at 27.6 V	at 55.2 V (24 x 2.3 V)	–	–
156 A	at 21.6 V	43.2 V (24 x 1.8 V)	–	–
35.2 A	–	–	–	at 248.4 V (108 x 2.3 V)
27.8 A	–	–	–	at 194.4 V (108 x 1.8 V)
Position 3	TXL830	TXL850	TXL870	TXL890
Current	0.092 Ω	0.184 Ω	1.24 Ω	3.52 Ω
300 A	at 27.6 V	at 55.2 V (24 x 2.3 V)	–	–
235 A	at 21.6 V	43.2 V (24 x 1.8 V)	–	–
100 A	–	–	at 124.2 V (54 x 2.3 V)	–
78.4 A	–	–	at 97.2 V (54 x 1.8 V)	–
70.5 A	–	–	–	at 248.4 V (108 x 2.3 V)
55.2 A	–	–	–	at 194.4 V (108 x 1.8 V)

BVM

Specifications are valid at an ambient temperature of +25°C, (77°F). Specifications are subject to change without notice.

Environment

Application field The instrument is intended for use in medium-voltage substations and industrial environments.
Altitude <2000 m (6500 ft) above sea level.

Temperature

Operating 0°C to +50°C (32°F to +122°F)
Storage & transport -20°C to +70°C (-4°F to +158°F)
Humidity 5% – 95% RH, non-condensing

CE-marking

LVD 2006/95/EC
EMC 2004/108/EC

General

Power supply

Mains voltage 100–240 V AC, 50/60 Hz
Power consumption 50 VA (max)
Protection Over voltage, reverse voltage, voltage transients, ESD

Dimensions

BVM unit 75 x 64 x 25 mm (3" x 2.5" x 1")
Carrying case 575 x 470 x 205 mm (22.6" x 18.5" x 8.1")

Weight

BVM unit 0.07 kg (0.15 lbs)
With accessories BVM system of 16 units 7 kg (15 lbs)
and carrying case BVM system of 31 units 8.8 kg (19 lbs)
BVM system of 61 units 12.5 kg (27 lbs)

Measurement section

Maximum number of BVM 2 x 120
Voltage ranges 0-5 V DC and 0-20 V DC
Resolution 1 mV both ranges
Inaccuracy < 0.1% of full scale ±0.01 VDC
Battery string voltage 300 V DC (max)
Measurement input impedance 1 MΩ

Index

A	
Alarm function.....	30
Ammeter.....	26
B	
Battery cables.....	28
Battery Voltage Monitor	35
BVM.....	35
BVM Cal Kit	37
C	
Calculating how many TORKELs and TXLs are needed.....	32
Clamp-on Ammeter.....	26
Clamp-on DC ammeter.....	28
Conducting a test.....	18
Constant current.....	19
Constant power	20
Constant resistance.....	21
Control panel	10
Current cables	18
Current, regulate.....	32
Current shunt.....	26
D	
Desired current.....	32
E	
EMERGENCY STOP.....	10
Emergency stop button.....	18
Ending the test.....	19
External current measurement	26
Extra Loads	34
G	
GRAPH.....	14
I	
ID Labels	13
Introduction.....	6
L	
Load profile.....	22
Load-providing capability.....	33
M	
Main menu.....	12
Menu system	12
O	
Optional cables.....	28
Optional equipment	34
P	
Pausing the test.....	19
Product description.....	6
R	
Regulate current.....	32
Resetting the alarm	30
S	
Safety	8
Safety instructions	8
Screen buttons	12
Side panel.....	11
Starting the test	19
stop button.....	18
Stop limit.....	13
Symbols on the instrumentl	8
T	
Temperature compensation.....	13
Test at constant current	19
Test configuration	13
TEST menu	12
Test method.....	12
Top panel.....	10
TORKEL Calc	16
TORKEL Control panel.....	10
TORKEL Viewer	16
TORKEL Win software.....	35
Troubleshooting.....	38
TXL.....	34
TXL Extra Loads.....	32
V	
Voltage range	18

W

Warning limit..... 13
Warranty 7
Warranty repair 7

Z

Zoom 15

Your "One Stop" Source for all your electrical test equipment needs

- Battery Test Equipment
- Cable Fault Locating Equipment
- Circuit Breaker Test Equipment
- Data Communications Test Equipment
- Fiber Optic Test Equipment
- Ground Resistance Test Equipment
- Insulation Power Factor (C&DF) Test Equipment
- Insulation Resistance Test Equipment
- Line Testing Equipment
- Low Resistance Ohmmeters
- Motor & Phase Rotation Test Equipment
- Multimeters
- Oil Test Equipment
- Portable Appliance & Tool Testers
- Power Quality Instruments
- Recloser Test Equipment
- Relay Test Equipment
- T1 Network Test Equipment
- Tachometers & Speed Measuring Instruments
- TDR Test Equipment
- Transformer Test Equipment
- Transmission Impairment Test Equipment
- Watthour Meter Test Equipment
- STATES® Terminal Blocks & Test Switches
- Professional Hands-On Technical and Safety Training Programs

Megger is a leading global manufacturer and supplier of test and measurement instruments used within the electric power, building wiring and telecommunication industries.

With research, engineering and manufacturing facilities in the USA, UK, Germany and Sweden, combined with sales and technical support in most countries, Megger is uniquely placed to meet the needs of its customers worldwide.

Megger is certified according to ISO 9001 and 14001. Megger is a registered trademark.

Megger Group Limited
UNITED KINGDOM
Dover, Kent CT17 9EN
ENGLAND

- | | |
|----------------------|------------------------|
| ■ AUSTRALIA | ■ POLAND |
| ■ BULGARIA | ■ ROMANIA |
| ■ CANADA | ■ RUSSIA |
| ■ CZECH REPUBLIC | ■ SINGAPORE |
| ■ CHINA | ■ SLOVAK REPUBLIC |
| ■ FRANCE | ■ SOUTH AFRICA |
| ■ GERMANY | ■ SPAIN |
| ■ HUNGARY | ■ SWEDEN |
| ■ INDIA | ■ SWITZERLAND |
| ■ INDONESIA | ■ TAIWAN |
| ■ KINGDOM OF BAHRAIN | ■ THAILAND |
| ■ KOREA | ■ UNITED ARAB EMIRATES |
| ■ MALAYSIA | ■ USA |
| ■ PAKISTAN | ■ VIETNAM |
| ■ PHILIPPINES | |



Megger

WWW.MEGGER.COM

Postal address:

Megger Sweden AB
Box 724
SE-182 17 DANDERYD
SWEDEN

Visiting address:

Megger Sweden AB
Rinkebyvägen 19
SE-182 36 DANDERYD
SWEDEN

T +46 8 510 195 00 seinfo@megger.com
F +46 8 510 195 95 www.megger.com